



30 - 2500 micron / 260 - 695 m³/h

HiFlux TS Strainer Filters for pressure systems are used where there is a need for efficient fine filtration with a large dirt capacity and low differential pressure.

The filters can be used as suction or pressure filters and have a simple and safe closure system which makes the cleaning time short, thereby maximizing the time the filters are in operation.

A compact design and a maximum built-in filter surface ensure the best possible flow and consequently a small differential pressure, long intervals between cleaning of the strainer element and low energy consumption.

The filter consists of two main elements

1. The filter housing, which is designed in accordance with current pressure vessel norms, in welded carbon steel or stainless acid-proof EN 1.4404 steel.
2. The strainer with its maximized surface can withstand a differential pressure of 2 bar.
The filter mesh is made of stainless steel in a hard-wearing weave.
The strainer is designed in such a way that it is easy to disassemble for efficient cleaning. This also ensures a quick and easy change of filtration degree if required.

In the standard version the direction of flow is from the inside and out through the filter insert. The dirt is retained in the filter strainer, which can be lifted out and cleaned with ease. It is possible to use the strainer filter with reverse flow. This means that the dirt is retained on the outside of the strainer and it is possible to remove the sludge from the filter by fitting a valve into the drain.

The filter can also be fitted with a magnetic system which makes it possible to retain magnetic particles. The magnetic insert is designed as an integrate part of the strainer insert for simple and fast handling in connection with cleaning.

The filters are fitted with two G¹/₂B outlets for connecting pressure gauges or a differential pressure indicator, if required.

Special versions in accordance with the customers' specifications. This typically includes different choice of materials, type/size/location of connections, different pressure limits and/or temperature levels. Approval in accordance with the PED directive 97/23/EC.

For other options see also **HiFlux LSS**, **HiFlux Micro Line 1050**, **HiFlux Micro Line 1050 SS** and **TS 1 - 5**.





TS 6 - 8 Strainer Filters

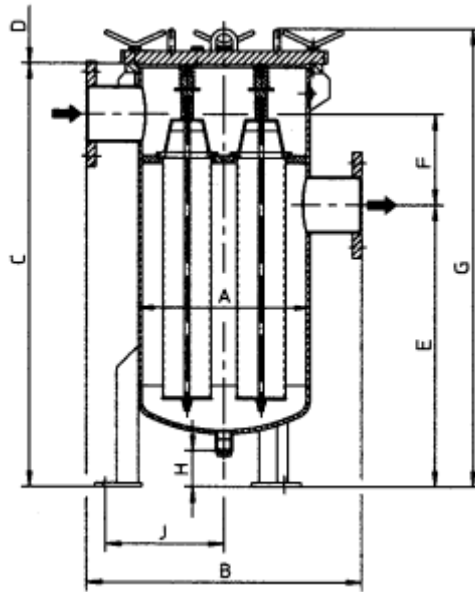

Type	A	B	C	D	E	F	G	H	J	Drain	Air vent.	Connection	Weight	Vol.	No. of fittings
	mm	mm	mm	mm	mm	mm	mm	mm	mm		Plug	DN	Kg	Liters	Units
TS 6-8520	406,4	650	1100	665	620	300	1200	115	280	G1B	G½B	200	190	185	6
TS 7-14910	508,0	750	1345	985	770	360	1445	220	329	DN50	G½B	250	~235	275	6
TS 8-19170	610	850	1620	1075	795	450	1620	220	383	DN50	G½B	300	~285	440	8

HiFlux standard type TS filters are supplied in carbon steel or stainless acid-proof EN 1.4404 steel.

Design pressure: 10 bar or 16 bar
 Test pressure: According to EN 13445
 Max. differential pressure: 2,0 bar
 Max. working temperature: 110 °C (water) or according to customer requirements
 Flange connection: EN 1092-1, 2 pcs. pressure outlet G½B
 Filtration area: 30-60-100-150-250-300-500-1000-1500-2500 micron

Capacity: (at a viscosity of 1 cSt

The filters can be supplied with a revolving crane arm for the cover.

Type	Strainer area cm ²	Capacity in m ³ /h at differential pressure 0.1 bar /micron							
		30	60	100	250	500	1000	1500	2500
TS 6-8520	8520	260	275	285	295	305	305	305	305
TS 7-14910	14910	415	440	455	470	485	485	485	485
TS 8-19170	19170	590	620	645	670	695	695	695	695

The filters can be fitted with the highly efficient HiFlux magnetic system for collection of magnetic particles.